

World's Smallest Wide Range Aerosol Spectrometer Mini-WRAS Model 1.371

A Symbiosis of an Optical Particle Counter and Electrical Mobility Spectrometer
Measuring from 0.01 to 35 μm with Wireless Operation



For many years GRIMM has been manufacturing different versions of aerosol spectrometers, which are used frequently in the field. More often than before the question is: Can the smallest particles be detected with these instruments? For the first time, this is now possible.

Two technologies were combined within the new **Mini-WRAS** (Mini Wide Range Aerosol Spectrometer): (a) the optical aerosol spectrometer and (b) a stepping mode operated electrode with faraday cup electrometer. Thus, the scattering light diameter of 0.25 to 35 micrometers and the diameter of the electrical mobility from 10 to 200 nanometers can be combined in a wide size range. Over 40 size channels are being measured every minute, ranging from 0.01 up to 35 micrometers and are released continuously.

With a total weight of only 8.2 kg, an integrated battery and advanced data communication interfaces (Bluetooth, USB, and RS-232), **this aerosol monitor is unique in the world.**

Customer's benefits

- Release of measurement data every minute as particle number in 41 equidistant size channels
- Portable, compact and with integrated rechargeable battery and air drying
- Distribution of count and mass or output according to occupational health standards EN 481 (inhalable, thoracic, alveolic) can be transferred via Bluetooth to our user-friendly software
- Readout of PM10, PM2.5, and PM1 values is also possible with the same software
- Does not need any kind of consumables (such as butanol)
- Does not need a radioactive source
- Sample air dryer for electrometer
- For the user, the **Mini-WRAS 1.371** offers the complete possibilities when saving or retrieving the measurement data. The data can be conveniently accessed and checked online via Bluetooth or RS-232 at the workplace per laptop or tablet. Additionally, the measurement data is stored on an USB flash drive.

Data interfaces of the Mini-WRAS 1.371: USB, Bluetooth, RS-232

Optical Measuring Cell (OPC)

GRIMM's more than 30 years of experience in manufacturing of aerosol spectrometers are reflected in the patented scattered light measurement cell of the OPC and its electronic signal output for every particle size. This know-how combined with high-quality material ensure precision and high data quality.

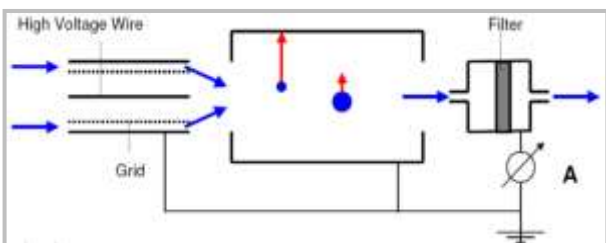
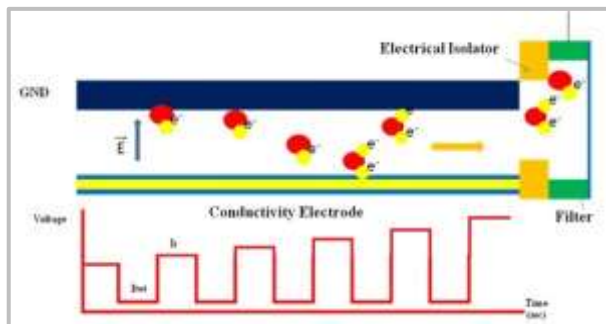
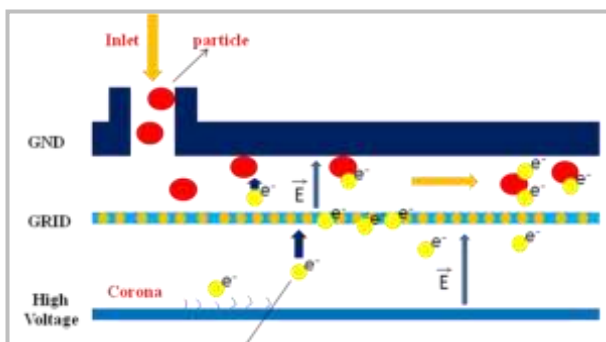
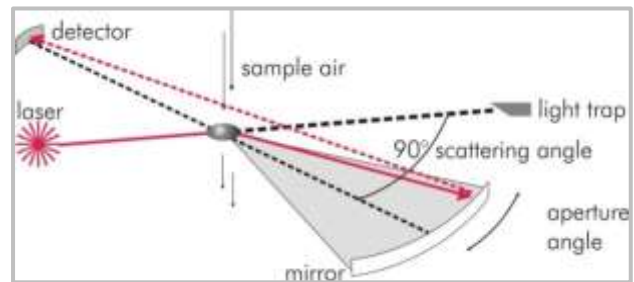

Electrical Mobility Spectrometer

The gas ions produced by the corona are accelerated towards a grid. The grid-voltage allows a small amount of ions to pass the grid. The ions move towards the surrounding concentric Ground-Electrode, where some of them diffuse onto particles and charge them. The charged aerosols enter a section, consisting of a round-shaped outer wall which is at electrical potential (GND) and a concentric conductivity electrode which operates at different voltages: The higher the voltage the more particles are removed, depending on their electrical mobility.

The deposition of the particles at the multiplexed electrode is a function of the particle diameter, the charge of the particle, the aerosol flow, the length and the diameters of the electrode and of the electrode voltage. By changing the voltage, a certain amount of particles is extracted from the aerosol flow. The higher the electrical mobility of the particles (smaller diameter or charged higher) the higher is the amount of particles that will deposit on the outer electrode.

Only particles with an electrical mobility less than a certain limit value will pass the electrode and are measured with a faraday cup electrometer.

The faraday cup electrometer detects the charges carried by the aerosol particles. The raw signals represent different currents depending on the voltage of the conductivity electrode.

For fine dust analysis in highest precision ranging from 10 nm to 35 μm , this top of the line device is unique and has no equal! The areas of use range from fine dust monitoring in industrial and manufacturing facilities to workplace measurements. With the advanced data communication interfaces, the **Mini-WRAS** offers its users utmost flexibility and mobility.

Specification Mini-WRAS 1.371



Measurement Data

Size channels:	41 channels, wide range from 10 nm to 35 μm 10 channels from electrical sensor, 31 channels from aerosol spectrometer: 10/ 14/ 19/ 27/ 37/ 52/ 72/ 100/ 139/ 193/ 253/ 298/ 352/ 414/ 488/ 576/ 679/ 800/ 943/ 1112/ 1310/ 1545/ 1821/ 2146/ 2530/ 2982/ 3515/ 4144/ 4885/ 5758/ 6787/ 8001/ 9431/ 11120/ 13100/ 15450/ 18210/ 21460/ 25300/ 29820/ 35150 [nm]
Count range:	1 to 3,000,000 particles/liter (aerosol spectrometer) 3,000 – 1,000,000,000 particles/cm ³ (electrical sensor)
Particle mass:	From 0.0001 mg/m ³ to 100 mg/m ³
Occupational classification (IAQ's):	Inhalable, thoracic and alveolic in accordance to EN 481 continuously and simultaneously
Environmental data:	PM10 and PM2.5, and PM1, PM0.5, PM0.1, continuously and simultaneously

Instrument Data

Reproducibility:	$\pm 3 \%$ over the total measuring range
Sample flow:	1.2 l/min $\pm 5 \%$ automatically regulated
Rinsing flow:	0.3 l/min, self-controlled, automatically optical cleaning on start-up and in stand-by mode
Laser wavelength:	660 nm (aerosol spectrometer)
Self-test:	Automatically after each start-up
Measurement intervals:	1 minute (10 x 6 s)
Storage intervals:	1 minute
Data storage:	USB flash memory
Communication:	Fully remotely controlled via Bluetooth (and RS-232)
Data output:	ASCII format and Excel (via software)
Power supply:	Li-Ion battery 14.4 V/4.8 Ah for continuous operation up to 8 hours; with internal charger
Power adapter:	18 VDC, maximum current 2.5 A
Dimensions:	34 x 31 x 12 cm (13.4 x 12.2 x 4.7 inches)
Weight and color:	8.2 kg (18.1 lb), grey housing
Operating conditions:	+4 to +40 °Celsius (39 to 104 °F), RH < 95 % (non-condensing), non-corrosive or explosive gases
Storage and transport:	-20 to +50 °Celsius (-4 to 122 °F), RH < 95 % (non-condensing)
Pressure range:	Absolute: 1013 hPa +/- 120 hPa, equates up to ca. 1,000 m ASL
Field service:	Integrated sample pipe and corona cleaning

Software

Version 1.378, based on LabView® for Windows XP upwards (see next page)

LabView® Software 1.378

With the new **software 1.378**, a user-friendly and powerful software based on LabView® has been developed and programmed by GRIMM. The software is compatible with all 32- and 64-bit Windows operating systems from XP and up. Values are displayed numerically or graphically as follows:

- Particle count concentration in all channels as particles/liter and particles/cm³
- Mass fraction: PM10, PM2.5, PM1 and simultaneously the occupational health values according to EN 481 (inhalable, thoracic, alveolic) in µg/m³. The updating, display and output of measuring data takes place every minute and is therefore not only suitable for data acquisition and analysis, but also for presentation.



Real time data per size channel

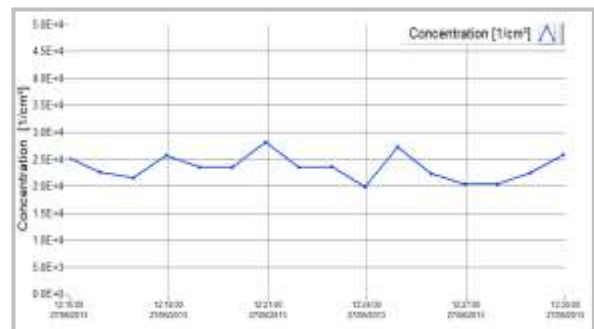

Total particle concentration

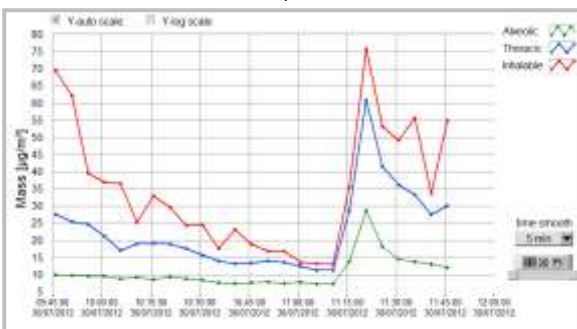

Occupational health mass over time



PM values over time

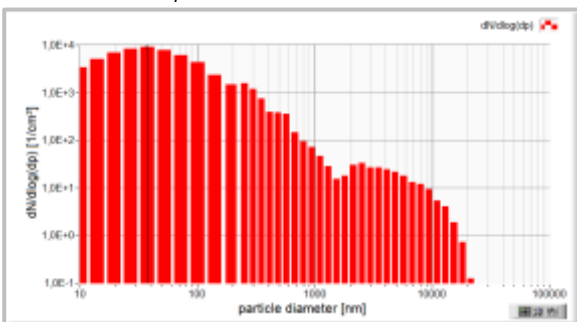

Particle size distribution by number

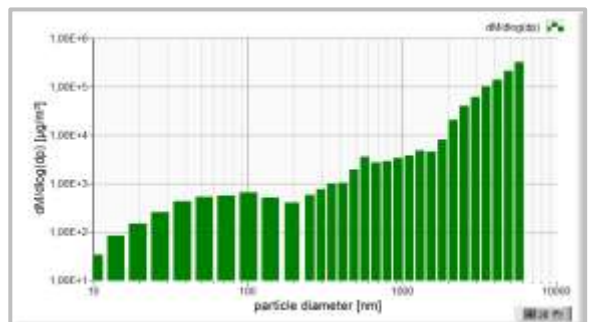

Particle size distribution by mass

Dealer



GRIMM Aerosol Technik GmbH

Dorfstrasse 9 • 83404 Ainring / Germany • www.GRIMM-aerosol.com
 Tel.: +49 (0)8654-578-0 • e-mail: sales@GRIMM-aerosol.com